

ELECTRIC SERVO MOTOR EQUATIONS AND TIME CONSTANTS

George W. Younkin, P.E.
 Life FELLOW – IEEE
 Industrial Controls Consulting, Div.
 Bulls Eye Marketing, Inc
 Fond du Lac, Wisconsin

In the analysis of electric servo drive motors, the equations for the motor indicates the presence of two time constants. One is a mechanical time constant and the other is an electrical time constant. Commercial servo motor specifications usually list these two time constants. However, it should be cautioned that these two time constants as given in the specifications are for the motor alone with no load inertia connected to the motor shaft. Since these two time constants are part of the motor block diagram used in servo analysis, it is important to know the real value of the time constants under actual load conditions.

There are two types of servo motors to consider. The first is the classical dc servo motor and the second is the ac servo motor often referred to as a brushless dc motor. The brushless dc motor is a three phase synchronous ac motor having a position transducer inside the motor to transmit motor shaft position to the drive amplifier for the purpose of controlling current commutation in the three phases of the motor windings.

A derivation of the motor equations and the electrical and mechanical motor time constants will be discussed for the dc motor followed by the ac motor. The dc motor equivalent diagram is:

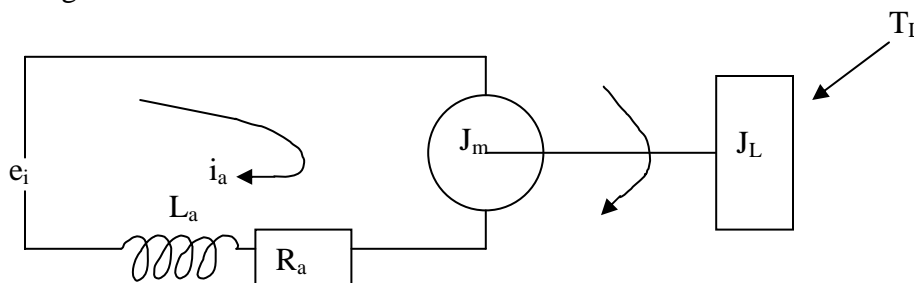

Figure 1

Where:

- e_i = Applied voltage (volts)
- i_a = Armature current (amps)
- J_T = Total inertia of motor armature plus load (lb-in-sec²)

$$\begin{aligned}
K_e &= \text{Motor voltage constant (v/rad/sec)} \\
K_T &= \text{Motor torque constant (lb-in/A)} \\
L_a &= \text{Motor winding inductance (Henries)} \\
R_a &= \text{Armature resistance (ohms)} \\
T_L &= \text{Load torque (lb-in)} \\
V_m &= \text{Motor velocity (rad/sec)} \\
\alpha &= \text{Acceleration (rad/sec}^2\text{)}
\end{aligned}$$

The steady state (dc) equations are:

$$e_i = i_a R_a + K_e V_m \quad (\text{Voltage equation}) \quad (1)$$

$$T = \text{Torque} = i_a K_T = J \alpha \quad (\text{Torque equation}) \quad (2)$$

For the general case, the differential equations are:

$$e_i = i_a R_a + L_a \frac{di_a}{dt} + K_e V_m \quad (3)$$

$$\text{Laplace operator } S = \frac{d}{dt} \quad (4)$$

$$e_i = R_a i_a + L_a S i_a + K_e V_m \quad (5)$$

$$e_i = (R_a + L_a S) i_a + K_e V_m \quad (6)$$

$$e_i = \left(\frac{L_a}{R_a} S + 1 \right) R_a i_a + K_e V_m \quad (7)$$

$$\text{Also: } T = K_T I_a = J_T \alpha = J_T V_m S \quad (8)$$

$$i_a = \frac{T}{K_T} = \frac{J_T V_m S}{K_T} \quad (9)$$

Combining equations gives:

$$e_i - K_e V_m = \left(\frac{L_a}{R_a} S + 1 \right) R_a \frac{J_T V_m S}{K_T} \quad (10)$$

Rearranging results in:

$$\frac{(e_i - K_e V_m) K_T}{\left(\frac{L_a}{R_a} S + 1 \right) R_a J_T S} = V_m \quad (11)$$

This last equation can be represented in block diagram form as:

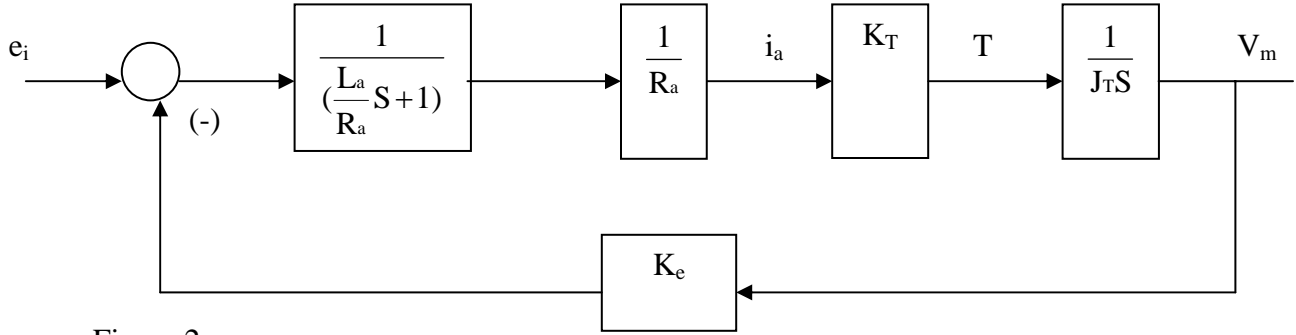

Figure 2

The closed loop equation ($\frac{C}{R} = \frac{G}{1+GH}$) for the above block diagram is:

$$\frac{V_m}{e_i} = \frac{K_T}{R_a J_T S \left[\left(\frac{L_a}{R_a} \right) S + 1 \right] + K_e K_T} \quad (12)$$

Rearranging gives:

$$\frac{V_m}{e_i} = \frac{K_T}{\left(R_a J_T \frac{L_a}{R_a} \right) S^2 + J_T R_a S + K_e K_T} \quad (13)$$

Dividing by $K_e K_T$ gives:

$$\frac{V_m}{e_i} = \frac{\frac{1}{K_e}}{\left(\frac{R_a J_T}{K_e K_T} \right) \left(\frac{L_a}{R_a} \right) S^2 + \left(\frac{R_a J_T}{K_e K_T} \right) S + 1} \quad (14)$$

From the last equation, the motor mechanical time constant, t_m , is:

$$t_m = \frac{R_a J_T}{K_e K_T} \quad [\text{sec}] \quad (15)$$

The total inertia, J_T , is the sum of the reflected inertia to the motor shaft plus the motor inertia. The resistance, R_a , is the motor winding resistance plus the external circuit resistance. Thus the motor mechanical time constant is summarized as:

$$t_m = \frac{\sum R_a J_T}{K_e K_T} \quad [\text{sec}] \quad (16)$$

Also, the motor electrical time constant is:

$$t_e = \frac{L_a}{\sum R_a} \text{ [sec]} \quad (17)$$

Therefore, the closed loop motor equation can be expressed as:

$$\frac{V_m}{e_i} = \frac{1/K_e}{t_m t_e S^2 + t_m S + 1} \quad (18)$$

From the general equation for a quadratic:

$$\frac{S^2}{\omega_m^2} + \frac{2\delta S}{\omega_m} + 1 \quad (19)$$

where: $\omega_m = \sqrt{1/t_m t_e}$

The damping factor is:

$$\delta = 0.5 t_m \omega_m = 0.5 t_m \sqrt{1/t_m t_e} = 0.5 \sqrt{t_m / t_e} \quad (20)$$

The mechanical and electrical time constants for a brushless dc motor have the same basic equations with some variations. For a brushless dc motor with a wye connected motor, the electrical circuit is:

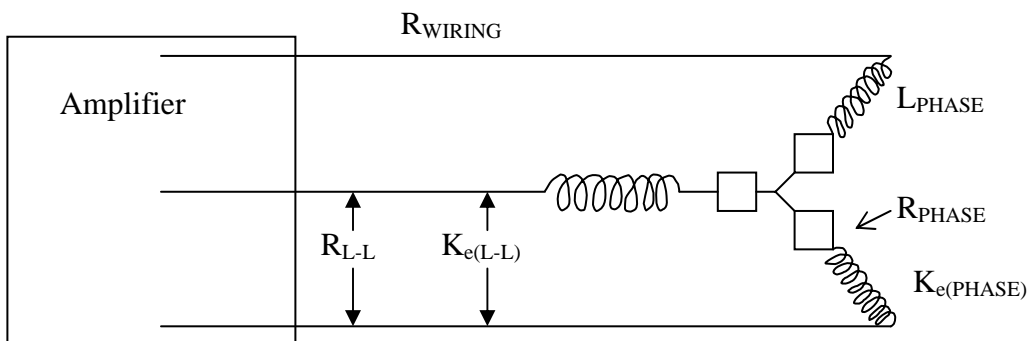

Figure 3

The mechanical time constant is:

$$t_m = \frac{\sum R_{\text{PHASE}} J_{\text{TOTAL}}}{K_{e(\text{PHASE})} K_T} \quad [\text{sec}] \quad (21)$$

where:

$$K_{e(\text{PHASE})} = \text{Motor voltage constant} = \frac{K_{e(L-L)}}{1.73} \left[\frac{\text{V-sec}}{\text{RAD}} \right] \quad (22)$$

$$K_T = \text{Motor torque constant} \left[\frac{\text{lb-in}}{\text{A}} \right] \quad (23)$$

$$R_{M(L-L)} = \text{Motor resistance [ohms]} \quad (24)$$

$$\sum R_{M(L-L)} = \text{Total motor circuit resistance} = 1.35 R_{M(L-L)} \quad [\text{ohms}] \quad (25)$$

$$\sum R_{M(\text{PHASE})} = \sum R_{M(L-L)} \times 0.5 = [\text{ohms}] \quad (26)$$

$$L_{L-L} = \text{Motor inductance} = [\text{Henries}]$$

$$J_{\text{TOTAL}} = \text{Motor armature inertia plus the reflected load inertia at the motor shaft} = [\text{lb-in-sec}^2]$$

Most manufacturers give the electrical parameters in line-to-line values. Thus some of these values must be converted to the phase values as shown above. Summarizing, the mechanical time constant can be computed as:

$$t_m = \frac{\sum \frac{R_{L-L}}{2} J_{\text{TOTAL}}}{\frac{K_{e(L-L)}}{1.73} K_T} \quad [\text{sec}] = 0.86 \frac{R_{l-l} J_{\text{total at motor}}}{K_{e(l-l)} K_T} \quad (27)$$

The electrical time constant for the brushless dc motor is computed as:

$$t_e = \frac{\text{Total inductive path}}{\text{Total resistive path}} = \frac{L_{L-L}}{\sum R_{m(L-L)}} \quad [\text{sec}] \quad (28)$$

Another factor affecting the mechanical time constant is the temperature. Most manufacturers specify the motor parameters at 25° C (cold rating). This implies that the magnet and wires are both at room temperature. However, the motors used in industry will operate hotter which could reach a magnet temperature of 80° C to 90° C in a 40° C ambient. The winding temperature is considerably more than that. Some means must be used to compensate for the motor parameters rated at 25° C. For those manufacturers that offer the hot rating on motor specification parameters, they should be used to calculate the time constants. The parameters of motor resistance, torque constant, and voltage constant should be adjusted, if needed, for the hot rating. The motor resistance will increase; the torque constant and voltage constant will decrease. However, contrary to their implied name both time constants are not of constant value. Rather, they are both functions of the motor's operating temperature.

The electrical resistance of a winding, at a specified temperature, is determined by the length, gauge and composition (i.e, copper, aluminum, etc.) of the wire used to construct the winding. The winding in the vast majority of industrial servomotors are constructed using film coated copper magnet wire. Based on the 1913 International Electrical Commission standard, the linear temperature coefficient of electrical resistance for annealed copper magnet wire is $0.00393/^\circ\text{C}$. Hence, knowing a copper winding's resistance at a specified reference or ambient temperature, the windings at temperatures above or below this ambient temperature is given by:

$$R(T) = R(T_0)[1+0.00393(T-T_0)] \quad (\text{eq a})$$

Where :

T = Winding's Temperature ($^\circ\text{C}$)

T_0 = Specified Ambient Temperature ($^\circ\text{C}$).

Using equation (a), a 130°C rise ($155^\circ\text{C}-25^\circ\text{C}$) in a copper winding's temperature increases its electrical resistance by a factor of 1.5109. Correspondingly, the motor's mechanical time constant increases by this same 1.5109 factor while its electrical time constant decreases by a factor of $1/1.5109 = 0.662$. In combination, the motor's mechanical to electrical time constant ratio increases by a factor of 2.28 and this increase definitely affects how the servomotor dynamically responds to a voltage command.

In consulting published motor data, many motor manufacturers specify their motor's parameter values, including resistance, using 25°C as the specified ambient temperature. NEMA, however, recommends 40°C as the ambient temperature in specifying motors for industrial applications, Therefore, pay close attention to the specified ambient temperature when consulting or comparing published motor data. Different manufacturers can, and sometimes do, use different ambient temperatures in specifying what can be the identical motor.

In the same published data servomotors are generally rated to operate with either a 130°C (Class B) or 155°C (Class F) continuous winding temperature. Although motors with a Class H, 180°C temperature rating are also available. Assuming the motor's resistance along with its electrical and mechanical time constants are specified at 25°C , it was just demonstrated that all three parameters significantly change value at a 155°C winding temperature. If the motor's winding can safely operate at 180°C the resistance change is even greater because equation (7.4-24) shows that a 155°C rise ($180^\circ\text{C}-25^\circ\text{C}$) in winding temperature increases its electrical resistance by a factor of 1.609. Hence, if the servomotor's dynamic motion response is calculated using the 25°C parameter values then this calculation overestimates the motor's dynamic response for all temperatures above 25°C .

In all permanent magnet motors there is an additional affect that temperature has on the motor's mechanical time constant only. As shown in eq (a) a motor's mechanical time constant changes inversely with any change in both the back EMF, K_e , and torque constant, K_T . Both K_e and K_T have the same functional dependence on the motor's air gap magnetic flux density produced by the motor's magnets. All permanent magnet motors are subject to both reversible and irreversible demagnetization. Irreversible demagnetization can occur at any temperature and must be avoided by limiting the motor's current such that, even for an instant, it does not exceed the peak current/torque specified by the motor manufacturer. Exceeding the motor's peak current rating can

permanently reduce the motor's K_e and K_T thereby increasing the motor's mechanical time constant at every temperature including the specified ambient temperature.

Reversible thermal demagnetization depends on the specific magnet material being used. Currently, there are four different magnet materials used in permanent magnet motors. The four materials are: Aluminum-Nickel-Cobalt (Alnico), Samarium Cobalt (SmCo), Neodymium-Iron-Boron (NdFeB), and Ferrite or Ceramic magnets as they are often called. In the temperature range, $-60^{\circ}\text{C} < T < 200^{\circ}\text{C}$, all four magnet materials exhibit reversible thermal demagnetization such that the amount of air gap magnetic flux density they produce decreases linearly with increasing magnet temperature. Hence, similar to electrical resistance, the expression for the reversible decrease in both $K_e(T)$ and $K_T(T)$ with increasing magnet temperature is given by :

$$K_{e,T}(T) = K_{e,T}(T_0)[1 - B(T - T_0)] \quad (\text{eq b})$$

In equation (b), the B-coefficient for each magnet material amounts to :

$$B(\text{Alnico}) = 0.0001/^{\circ}\text{C}$$

$$B(\text{SmCo}) = 0.00035/^{\circ}\text{C}$$

$$B(\text{NdFeB}) = 0.001/^{\circ}\text{C}$$

$$B(\text{Ferrite}) = 0.002/^{\circ}\text{C}$$

Using equation (b) it can be calculated that a 100°C rise in magnet temperature causes a reversible reduction in both K_e and K_T that amounts to 1 percent for Alnico, 3.5 percent for SmCo, 10 percent for NdFeB. And 30 percent for Ferrite or Ceramic magnets.

Like the motor's electrical resistance, most motor manufacturers specify the motor's K_e and K_T using the same ambient temperature used to specify resistance. However, this is not always true and it is again advised to pay close attention as to how the manufacturer is specifying their motor's parameter values.

Combining the affects of reversible, thermal demagnetization with temperature dependent resistance, the equation describing how a permanent magnetic motor's mechanical time constant increases in value with increasing motor temperature amounts to:

$$\tau_m(T) = \tau_m(T_0) \frac{[1 + 0.00393(T - T_0)]}{[(1 - B(T - T_0))^2]} \quad (\text{eq c})$$

Notice in (eq c) that the magnet's temperature is assumed equal to the motor's winding temperature. Actual measurement shows that this assumption is not always correct. Motor magnets typically operate at a lower temperature compared to the winding's temperature. However this conservative approximation is recommended and used.

An example will be given to illustrate a change in time constants. To raise the mechanical time constant to a 155°C temperature rating inside a Ferrite magnet motor, for example, the resistance increase will be-

$$R(155^{\circ}\text{C}) = R(25^{\circ}\text{C}) + 0.00393/^{\circ}\text{C} \times (155 - 25) \times R(25^{\circ}\text{C}) = 1.5109 R(25^{\circ}\text{C})$$

The voltage constant K_e and torque constant K_T will be lowered. Since the magnet material is 10°C - 15°C cooler than the windings the K_e and K_T will be-

$$K_e(140^{\circ}\text{C}) = K_e(25^{\circ}\text{C}) - 0.002/^{\circ}\text{C} \times (140 - 25) K_e(25^{\circ}\text{C}) = 0.77 K_e(25^{\circ}\text{C})$$

The mechanical time constant will increase by-

$$t_m(155^{\circ}\text{C}) = 1.5109 / (0.77)^2 = 2.54 t_m(25^{\circ}\text{C})$$