

Dual axis servo module

MC

M3-40A

2 axis servo module

- ▶ Advanced floating point position loop
- ▶ Up to 16 axes per system
- ▶ Encoder rate 17.5 MHz
- ▶ Updates both position loops in 500 μ sec
- ▶ Commands: linear, S-curve, Cam, Spline, Gear, Move on a gear, Virtual master
- ▶ < 1 μ sec registration response
- ▶ 6 PLS outputs with 0.25 μ sec activation
- ▶ High-speed, 32-bit motion processor
- ▶ Optically and electrically isolated
 - Each channel has an electrically isolated analog ground
 - Each channel is individually optically isolated
- ▶ Precision 16-bit command signal

General specifications

Number of axes	2
Axis type	Servo
Servo drive command	Analog torque or velocity
Digital inputs per axis	5
Digital outputs per axis	5
Connection	Removable terminal block
Connection type	Tension clamp
Terminal block part number	069-622210
Terminal wire size (UL 1059)	18 - 22 AWG
Test point	All connections
Module size	1 rack slot (0.75"/19 mm)
Bus power required (5 VDC)	0.26 mA
Isolation rating	500 VDC
Operating temperature	
Horizontal installation	0 - 40°C
Vertical installation	0 - 35°C
Storage temperature	-25 - 85°C
Humidity	5 - 95% non-condensing



Minimum hardware revision	A
Minimum firmware revision	1.02
Minimum operating system revision	5.00.90
Documentation number: 950-534001-010	

Dual axis servo module

MC

M3-40A

Performance specifications

Parameter	Value
Position range	64-bit
Position resolution	±1 count
Velocity range	±17.5M counts/sec
Velocity resolution	±1 count/sec
Position loop update	500 µsec/2 axes
Command resolution	16-bit
Closed loop feature	Encoder
Encoder feedback type	5 V - differential quadrature
Max encoder rate	17.5 MHz

Electrical specifications

Parameter	Value
Command signal voltage	Bipolar single-ended ±10V (5mA max)
Max encoder input voltage	6 VDC
Encoder Turn ON/OFF threshold	±200 mV
Encoder termination resistor	100Ω (10%)
Registration input type	VDC sourcing
Registration response	<1 µsec
Registration Turn ON threshold	0.53 * VS
Registration Turn OFF threshold	0.32 * VS
Max registration voltage	VS
Max ON registration current	2.6 mA DC
Registration input resistance to VDC RTN	12 KΩ (10%)
Output current:	
per channel	±0.5 A
per module	±3 A
per controller	±8 A
Output voltage:	
V _{OL} (sinking) @ 100 mA	0.4 VDC
V _{OL} (sinking) @ 0.5 A	2 VDC
V _{OH} (sourcing) @ 100 mA	VS - 0.4 VDC
V _{OH} (sourcing) @ 0.5 A	VS - 2 VDC

Additional features

Parameter	Value
Per axis motion I/O	
Inputs:	
Assignable ¹	5
Registration ²	2
Capture speed	< .25 µsec
Outputs:	
Assignable ¹	5
Move types:	Linear, S-curve, Cam, Spline, Gear, Move on a gear, Virtual master
Servo loop	PID, PDF
Feedforward	Velocity, acceleration
Distributed feedback/backlash compensation	Dual encoder option

Notes

1. General purpose inputs and outputs can be assigned special functions such as limits, enable, running, etc. or used programmatically. See Doc. No. 951-530017: QuickMotion Reference Guide for details.
2. Any two inputs can be configured as high-speed registration inputs (response time < 0.25 µsec).
3. Outputs 3, 4, and 5 can be set up as high-speed PLS outputs (PLS activation < 0.25 µsec).

2 axis servo module

Terminal block connections

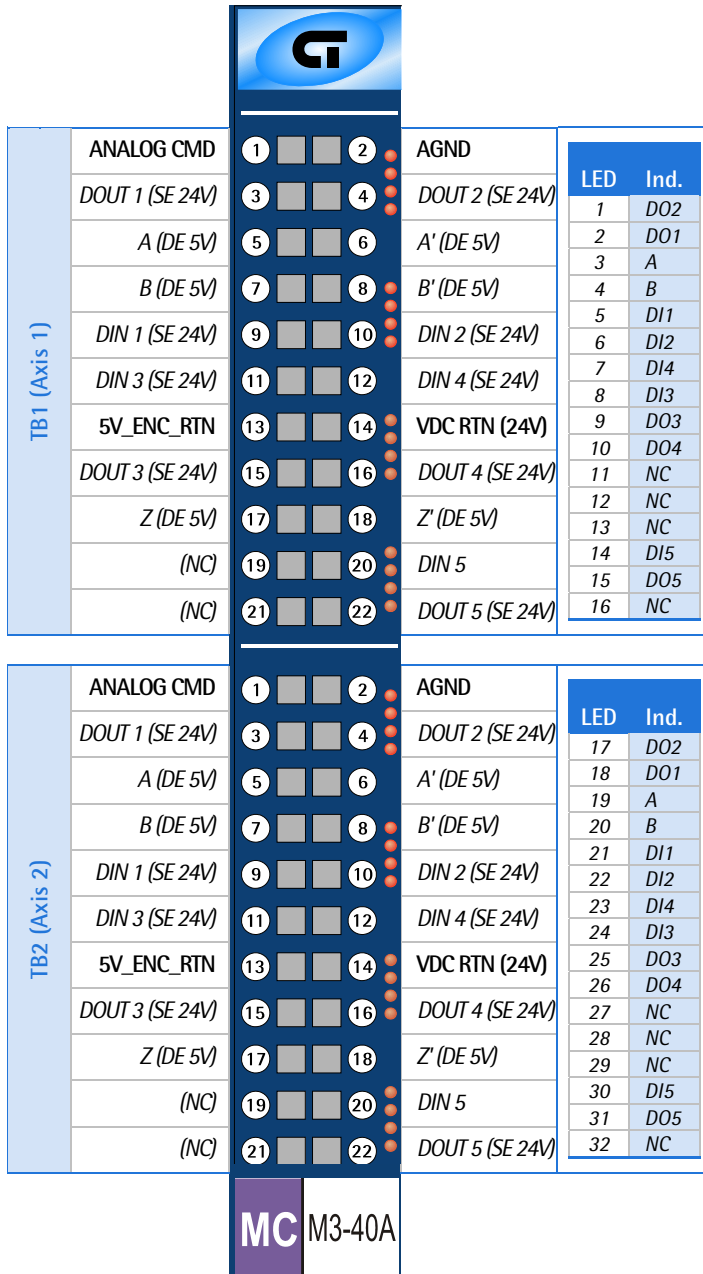

Special I/O Functions

- **16 HS Counters (10 MHz):** All five inputs as well as the A, B, and Z signal pins on each axis connector can be configured as high-speed counters.
- **Period Measurement (0.1 μsec accuracy):** Two pairs of inputs on each axis can be set up to measure the time between activation of the first and second input in the pair. Ideal for high-speed measurement and frequency measurement.
- **Frequency Outputs:** Three outputs on each axis can generate a programmable frequency up to 500 KHz.
- **Pulse Outputs:** All ten outputs can be pulsed for a programmable time value with an accuracy of 0.5 msec.
- **Programmable Limit Switch Outputs:** Three outputs on each axis can be configured to automatically turn on and off as a function of the encoder position. Up to sixteen on/off positions can be configured per axis. The on/off positions can be changed programmatically on-the-fly. This is especially useful to compensate for lead or lag time based on operating speed.

Dual axis servo module

MC

M3-40A

Application Information

Analog Command Application

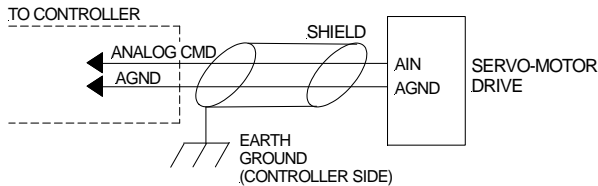

All Single-ended Inputs Application

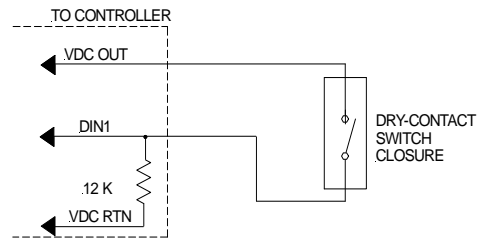

Differential Encoder/Counter Application

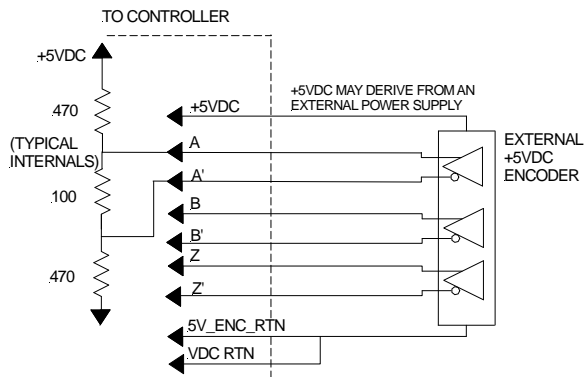

Digital Output Applications

Sourcing

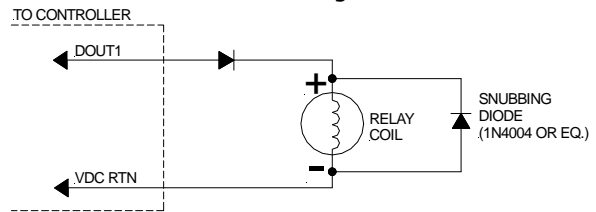

Notes

1. Shields must be terminated on the controller side of the cable.
2. External power supply commons must be tied to the controller's supply voltage return (VDC RTN) and/or analog common (ACOM).
3. The information and illustrations contained herein are the property of Control Technology Corporation and are subject to change without notice. Data based on $V_S = 24\text{ VDC}$ @ 25°C unless otherwise noted. For additional information and/or updates, visit www.ctc-control.com. Copyright © 2007 - 2010 Control Technology Corporation. All Rights Reserved.
4. V_S refers to the voltage supply of the controller. $VDC\ OUT = V_S$ (DC voltage supplied to controller's power supply).
5. If an external 5V power supply is used for the encoder, the external power supply's VDC RTN must be tied to 5V_ENC_RTN.
6. For single-ended counter or encoder input signals, tie A', B', and Z' to 5V_ENC_RTN.